

VALVOLA TERMOSTATIZZABILE DIRITTA PER RADIATORI
STRAIGHT THERMOSTATIC RADIATOR VALVES

Valvola termostattizzabile destinata alla regolazione ed intercettazione del fluido circolante nei radiatori degli impianti di climatizzazione.

Thermostatic valve for the regulation and interception of the fluid circulating in the radiators of the air conditioning systems.

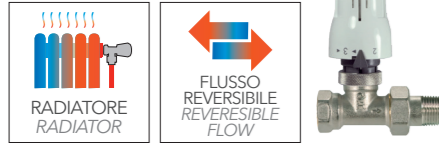

106

CONFORME A
SERIE F EN 215

CON PREREGOLAZIONE DELLA PORTATA
WITH FLOW PRESETTING

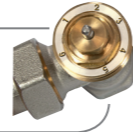

ATTACCO TUBO FERRO
CONNECTION IRON PIPE

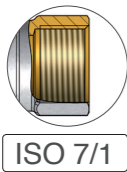
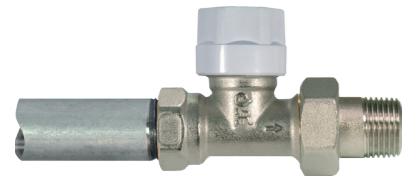

Prodotto a bassa inerzia termica in abbinamento alla testa TH 101.
Product with low thermal inertia in connection with the thermostatic head 101.

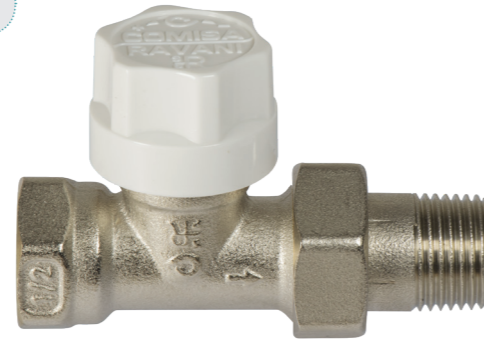

MISURE SIZE	PN	Kvs
3/8"	10	1,15
1/2"	10	1,15
3/4"	10	1,36
1"	10	

Pressione massima / Maximum pressure
10 Bar

Temperatura d'esercizio / Operating temperature
0° C + 120° C

Valore massimo Δp / Maximum Δp
1 Bar

Fluidi / Fluid
Acqua e soluzioni glicolate (max 30%)
Water and glycol solutions (maximum 30%)

- Innovativo sistema a 6 posizioni per la regolazione del flusso
 - Valvola termostattizzabile diritta per radiatore
 - Collaudi al 100% delle tenute verso l'interno e verso l'esterno sull'intero lotto prodotto
 - Corpo in ottone CW617N conforme a EN 12165, stampati a caldo sabbiati e nichelati prima della lavorazione
 - Otturatore in ottone CW614N conforme a EN 12164
 - Ottone conforme a: DIN 50930-6; D.M.174; Direttiva 2011/65/EC (ROHS II)
 - O-rings in EPDM
 - Manopola in ABS bianco
- Innovative system 6 positions for regulating the flow
 - Straight thermostatic valve for radiator with shutter soft seal
 - Testing at 100% (detailed inspection) of the seals inwards and outwards on the whole production batch
 - Body in brass CW617N in conformity with EN 12165, hot-pressed sand blasted and nickel plated before machining
 - Shutter in brass CW614N, in conformity with EN 12164
 - Brass in conformity with: DIN 50930-6; D.M.174; Directive 2011/65/EC (ROHS II)
 - O-Rings in EPDM
 - Handwheel in white ABS

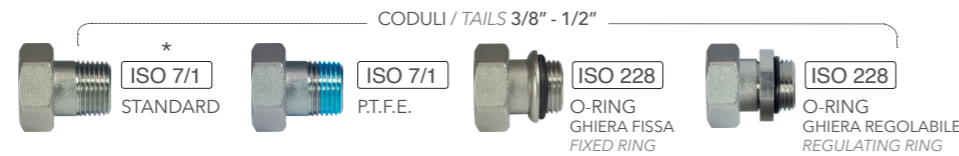

Certificazioni / Certifications



Filetto di connessione

Valvola conforme EN10226-1 (ISO7/1)
Bocchettone standard e P.T.F.E. conforme a EN10226-1 (ISO7/1)
Bocchettone con O-Ring conforme a EN ISO 228
* Bocchettone standard per 3/4" conforme a EN ISO 228

Threaded connection

Valve in conformity with EN10226-1 (ISO7/1)
Standard nut and tail and PTFE in conformity with EN10226-1 (ISO7/1)
Nut and tail with O-Ring in conformity with EN ISO 228
* Standard nut and tail for 3/4" size in conformity with EN ISO 228

• Attenzione (1")

NB: La valvole DN 25 non ha la prerogazione di portata

• Attention (1")

The DN 25 valve does not have a flow preset

Valvola abbinabile con detentore
Valve combined with lockshield



VALVOLA TERMOSTATIZZABILE DIRITTA PER RADIATORI
STRAIGHT THERMOSTATIC RADIATOR VALVES

Valvola termostattizzabile destinata alla regolazione ed intercettazione del fluido circolante nei radiatori degli impianti di climatizzazione.

Thermostatic valve for the regulation and interception of the fluid circulating in the radiators of the air conditioning systems.

106

CONFORME A
SERIE F EN 215

CON PREREGOLAZIONE DELLA PORTATA
WITH FLOW PRESETTING

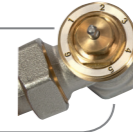

Materiali / Materials

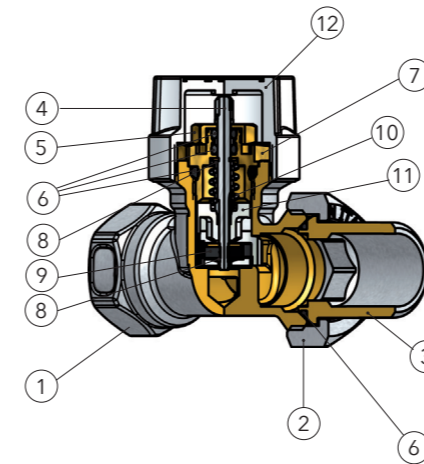

	DESCRIZIONE	DESCRIPTION	MATERIALE / MATERIAL
1	CORPO	BODY	OTTONE / BRASS CW617N UNI EN 12165
2	DADO	SHUTTER	OTTONE / BRASS CW617N UNI EN 12165
3	BOCCHETTONE	TAIL PIECE	OTTONE / BRASS CW617N UNI EN 12165
4	ASTA DI COMANDO	SPINDLE	ACCIAIO / STEEL AISI 316
5	GHIERA VITONE	HEAD SCREW	OTTONE / BRASS CW614N UNI EN 12164
6	O-RING	O-RING	EPDM
7	CORPO VITONE	BODY SCREW	OTTONE / BRASS CW614N UNI EN 12164
8	SEEGER	SEEGER	ACCIAIO / STEEL AISI 304
9	GUARNIZIONE	GASKET	EPDM
10	MOLLA	SPRING	ACCIAIO PER MOLLE / STEEL
11	ANELLO DI REGOLAZIONE DELLA PORTATA	DEVICE FOR PRESETTING	RESINA ACETALICA / ACETAL RESIN
12	MANOPOLA	HANDWELL	ABS BIANCO / ABS WHITE

Dimensioni / Dimensions

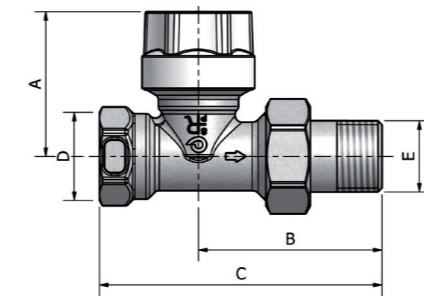

MISURE / SIZE	A	A1	B	C	D	E
3/8"	42	58	51,5	76	Rp 3/8"	R 3/8"
1/2"	42	58	54	83	Rp 1/2"	R 1/2"
3/4"	42	58	61,5	94	Rp 3/4"	G 3/4"
1" •	43	59	78,5	123,5	Rp 1"	G 1"

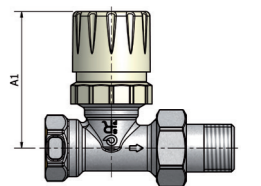

Diagrammi perdite di carico / Pressure drop chartes

3/8" - 1/2"

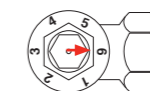
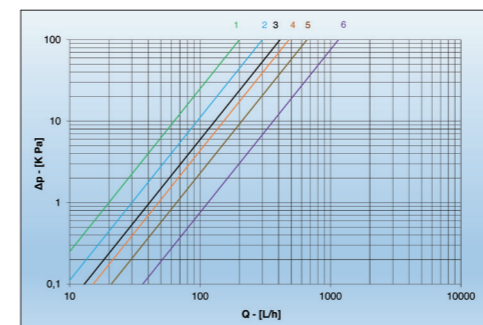

Riferita alla posizione 6 del corpo in abbinamento alla testa termostatica 101

Referred to the position 6 of the body combined with the thermostatic head 101

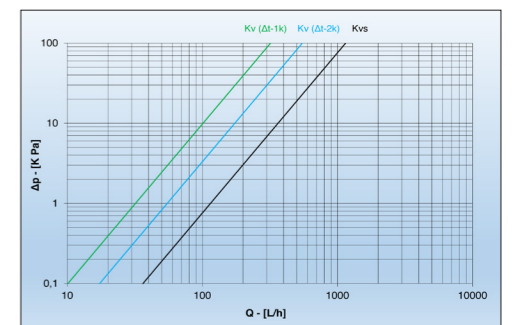

Per il grafico relativo alle misura 3/4" e 1" pag.73 .
Chart of size 3/4" and 1" pag.73.